

Light Gauge Panels



Agricultural • Light Commercial • Residential

45 YEAR FINISH WARRANTY	40 YEAR FINISH WARRANTY	20 YEAR FINISH WARRANTY
MS Colorfast45®	ColorFit40™	Versa20™
26 Ga. & 29 Ga.	29 Gauge	29 Gauge
10 Year Edge Warranty	No Edge Warranty	No Edge Warranty

The Metal Sales Advantage

Metal Sales Manufacturing Corporation continues to lead the industry with time-tested quality products dedicated to the agricultural, residential, industrial, commercial and architectural customer. Some features include:

- Extensive and diverse product line. With a wide variety of profiles and colors from which to choose, Metal Sales can satisfy any project need for metal roofing and siding.
- Industry-leading paint finishes and warranties. Up to 45 year warranties available for product endurance.
- 21 manufacturing facilities across the United States, strategically located to provide superior service and convenience.
- Company-owned delivery trucks. Many equipped with boom unloading capabilities for job-site delivery.
- The largest sales force in the industry backed by service and experience since 1963.
- Technical Services. In-house shop drawings, product application information, and design specifications available.

Metal Sales Advantage ... unmatched.

*Review our most popular profiles in this catalog.
For additional options visit our website.*



Multiple Layers of Protection

The ultimate lifespan of a steel roof and wall panels depends on the quality of the coating system that protects it. Inferior coatings will not protect the steel substrate from harsh elements. Metal Sales is committed to using only the highest quality products for its coating systems. Our paint systems offer multi-layer protection that is proven to be superior in every respect – layer by layer.

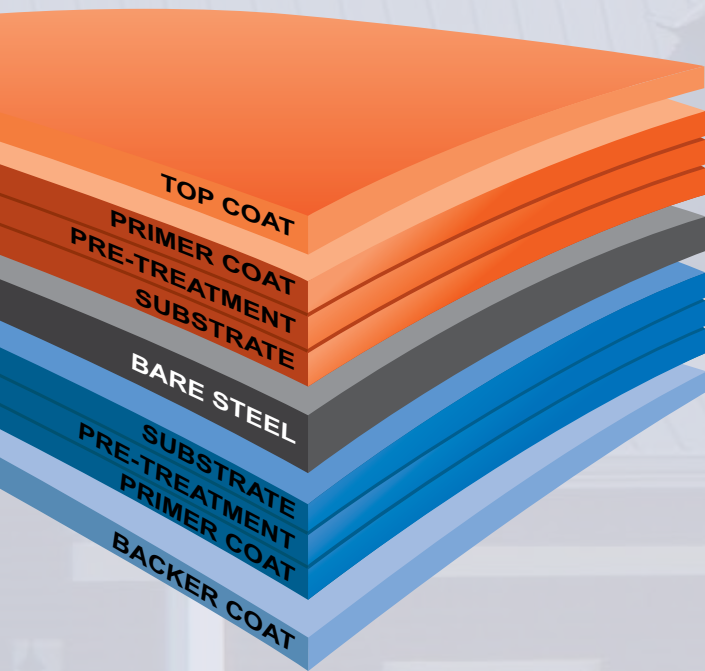

TOP COAT | Premium ceramic and inorganic pigment for exceptional color, durability and gloss retention

PRIMER COAT | UV and moisture resistant, key component to product longevity

PRE-TREATMENT | Promotes adhesion, moisture and corrosion resistance

GALVALUME OR GALVANIZED | Metallic coating barrier protection on base steel, inhibits corrosion

BARE STEEL | Mill certified, meeting ASTM standards

BACKER COAT | Finish coat on backside, covers primer and insures consistent color

Elite Series • G100

45 YEAR FINISH WARRANTY

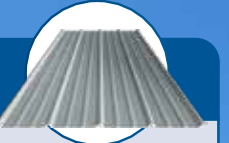

With Elite Series, you'll get all of the outstanding features of our original 36" panel products, plus much more. Our Elite Series panels feature G100 galvanizing (one of the heaviest in the industry) and are coated with our industry-leading MS Colorfast45 paint finish, to provide the longest life possible for your agricultural, light commercial or residential projects.

Quality features include 29 gauge steel, G100 galvanizing, a 45 year warranty, 10 year edge-corrosion protection, time-tested profiles (Pro-Panel II, Classic Rib and Bi-Rib), a wide variety of ENERGY STAR® colors and a full line of matching flashings and trims to complete your project.

Note: Elite Series panels are available at select Metal Sales locations.

MS Colorfast45®

45 YEAR FINISH WARRANTY

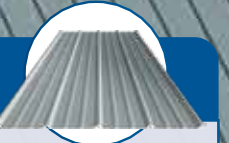

MS Colorfast45, a premium SMP finish uses a combination of select inorganic and ceramic pigments for coloring. These pigments offer years of exceptional performance in rough weather and resist color change, acids, alkalis and oxidizing agents found in harsh environments.

and the results are truly remarkable.

MS Colorfast45 has undergone more than a decade of rigorous real-world weathering tests conducted in south Florida

The same high-performance pigments that resist color change are also designed to reflect the sun's solar energy before it can be absorbed as heat, keeping the metal roof cooler than traditional roofs. The infrared-reflective pigments can lower a roof surface temperature significantly. The result is a building that stays cooler and reduces energy use.

ColorFit40™

40 YEAR FINISH WARRANTY

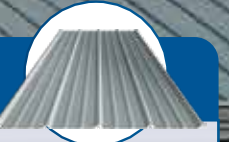

As a leading metal roof and wall manufacturer for more than 55 years, Metal Sales is committed to supplying our customers with the right finish for their projects, no matter the size, building type or budget.

paramount to your success. ColorFit40 comes with a 40 year warranty backed by the company with the staying power to honor it. Combine that with the superior sales and technical support you have come to expect from Metal Sales and you have a building envelope that will last for decades and decades.

Metal Sales ColorFit40, a superb multi-layered coating system, delivers the quality and reliable performance that is

Versa20™

20 YEAR FINISH WARRANTY

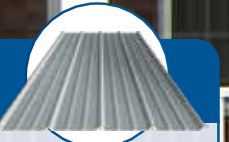

If its time to cover a barn, shed, utility building or any other project that may require painted metal roof and wall panels, consider Metal Sales Versa20 paint system available on many of our multi-purpose panel profiles. Versa20 is available in select colors and offer an economical solution for your next roof, wall or liner project.

A multi-year finish warranty makes Versa20 an excellent value option for just about any metal roof or wall project. Versa20 is your low-cost roof and wall alternative.

Note: Versa20 panels are available at select Metal Sales locations.



CLASSIC RIB®

- Roof, wall, liner, ceiling and soffit applications
- 29 gauge and 26 gauge
- 36" panel coverage
- Bell-top, trapezoidal ribs on 9" centers
- 3:12 minimum roof slope
- Elite Series, MS Colorfast45, ColorFit40, Versa20, Galvalume and Galvanized
- Applies over open framing or solid substrate

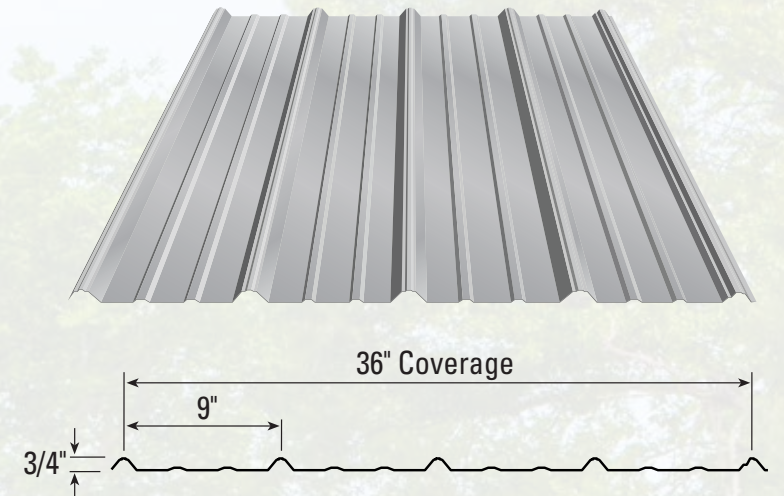

PRO-PANEL II®

- Roof, wall, liner, ceiling and soffit applications
- 29 gauge and 26 gauge
- 36" panel coverage
- Trapezoidal ribs on 9" centers
- 3:12 minimum roof slope
- Elite Series, MS Colorfast45, ColorFit40, Versa20, Galvalume and Galvanized
- Applies over open framing or solid substrate

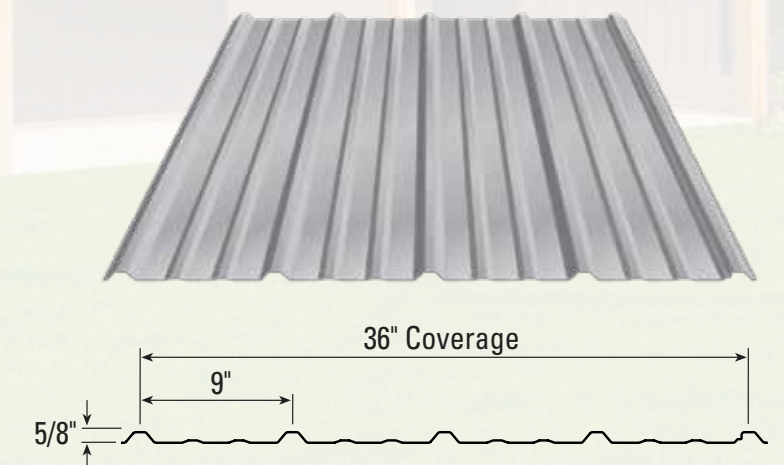

2.5" CORRUGATED

- Roof, wall, liner, ceiling and soffit applications
- 29 gauge and 26 gauge
- 21-2/3" roof panel coverage
- 24" wall panel coverage
- Corrugated ribs on 2-2/3" centers
- 3:12 minimum roof slope
- MS Colorfast45, Versa20, Galvalume and Galvanized
- Applies over open framing or solid substrate

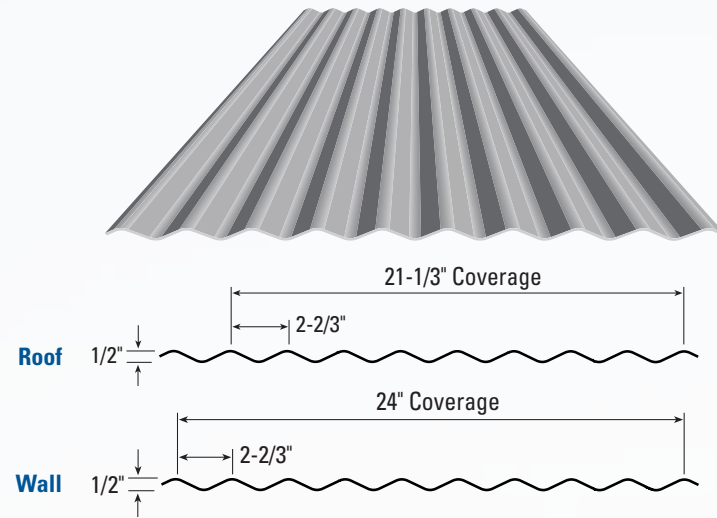

1.25" CORRUGATED

- Roof, wall, liner, ceiling and soffit applications
- 29 gauge and 26 gauge
- 24" panel coverage
- Corrugated ribs on 1-1/4" centers
- 3:12 minimum roof slope
- MS Colorfast45, Versa20, Galvalume and Galvanized
- Applies over open framing or solid substrate

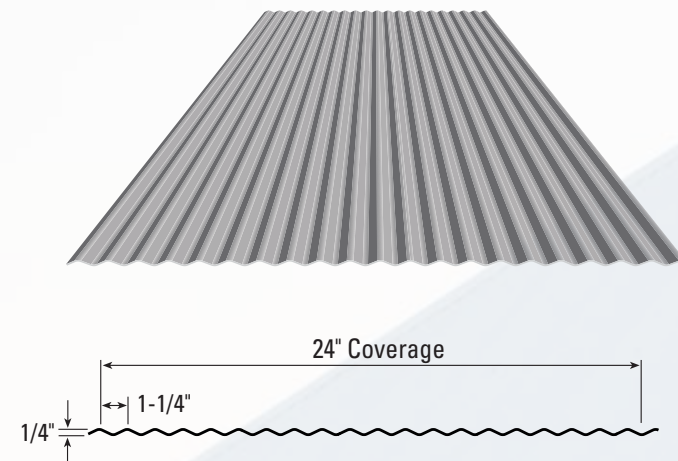

5V-CRIMP

- Roof panel
- 29 gauge and 26 gauge
- 24" roof panel coverage
- Traditional "V" rib profile
- 3:12 minimum roof slope
- MS Colorfast45, Galvalume and Galvanized
- Applies over solid substrate

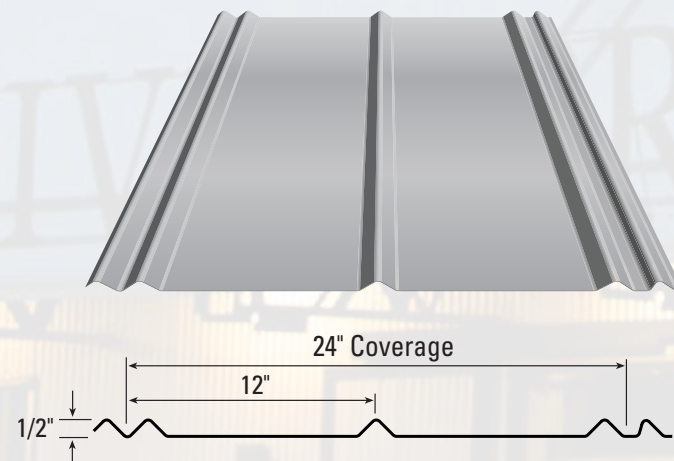



PBR-PANEL / R-PANEL

- Roof, wall, liner and soffit applications
- 26 gauge and 29 gauge
- 36" roof panel coverage
- Trapezoidal ribs on 12" centers
- 1:12 minimum roof slope
- MS Colorfast45, Galvalume and Galvanized
- Applies over open framing or solid substrate

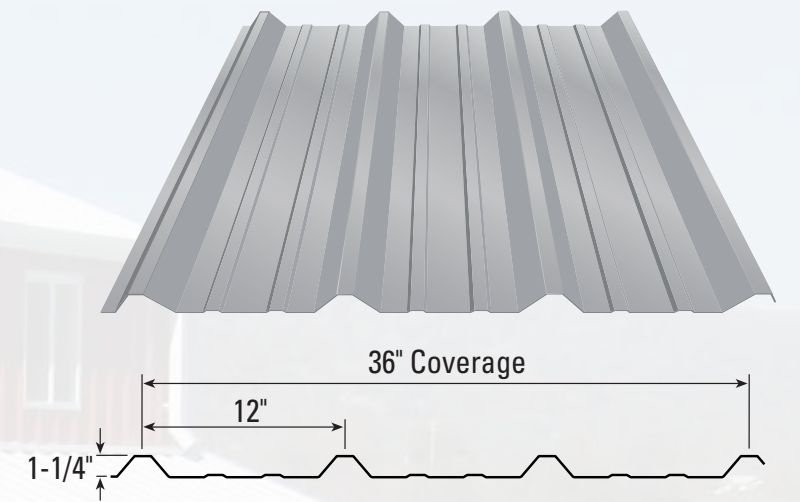

DL-3 PANEL

- Roof, wall, liner and soffit applications
- 29 gauge
- 36" roof panel coverage
- Trapezoidal ribs on 3" centers
- 3:12 minimum roof slope
- MS Colorfast45 and Galvanized
- Applies over open framing or solid substrate

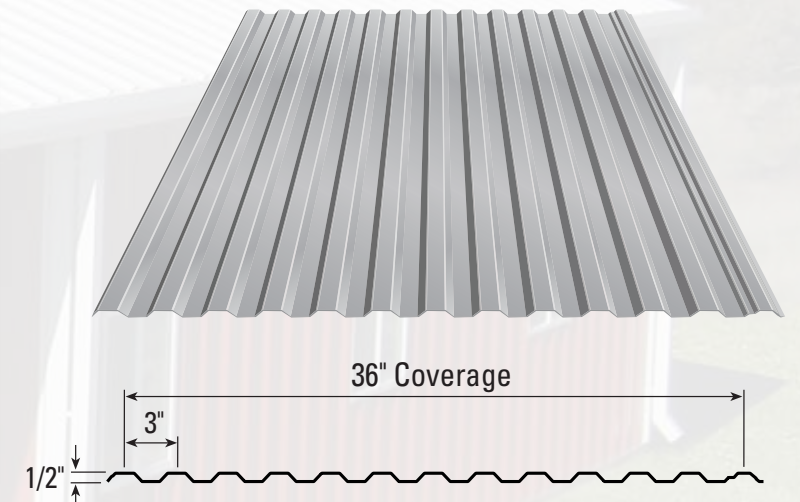

STRONGPANEL

- Roof, wall and liner applications
- 29 gauge
- 36" roof panel coverage
- Classic board and batten design on 9" centers
- 3:12 minimum roof slope
- MS Colorfast45, Galvalume and Galvanized
- Applies over open framing or solid substrate

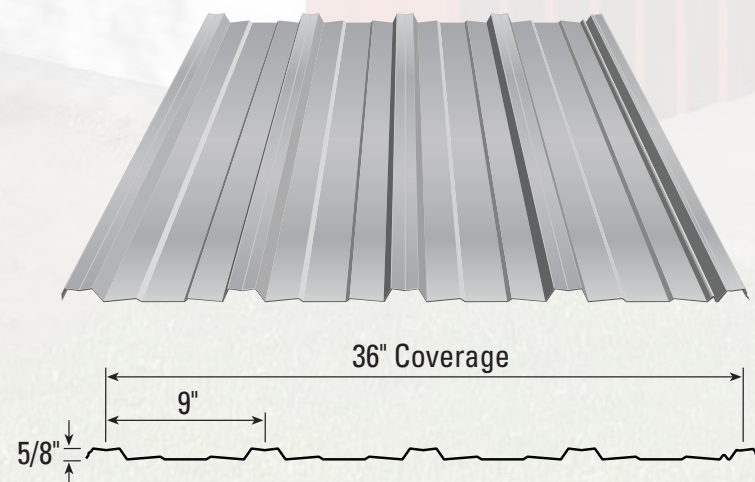

BI-RIB

- Roof, wall, liner and soffit applications
- 29 gauge
- 36" roof panel coverage
- Double trapezoidal ribs on 9" centers
- 3:12 minimum roof slope
- Elite Series, MS Colorfast45, Versa20, Galvalume and Galvanized
- Applies over open framing or solid substrate

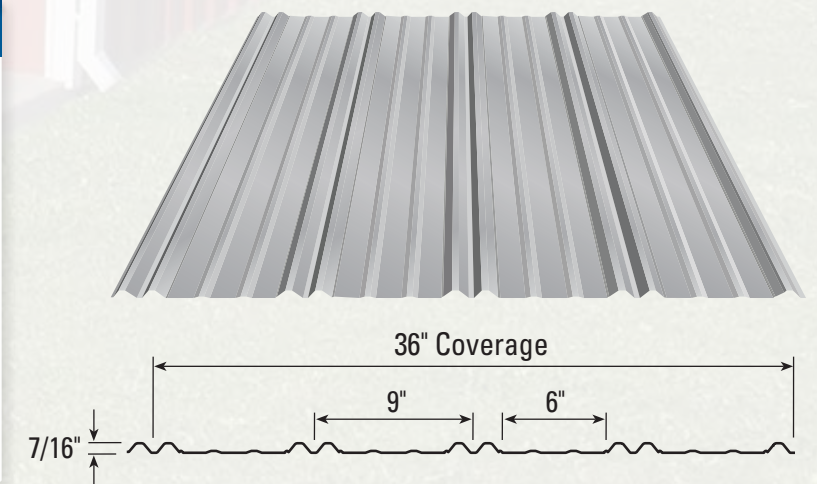

METAL SALES BRANCH LOCATIONS



ANCHORAGE, ALASKA

4625 Old Seward Highway
Anchorage, AK 99503
866.640.7663 • 907.646.7664/Fax

BAY CITY, MICHIGAN

5209 Mackinaw Road
Bay City, MI 48706
888.777.7640 • 888.777.0112/Fax

DEER LAKE, PENNSYLVANIA

29 Pinedale Industrial Road
Orwigsburg, PA 17961
800.544.2577 • 800.544.2574/Fax

DENVER, COLORADO

7990 East I-25, Frontage Road
Longmont, CO 80504
800.289.7663 • 800.289.1617/Fax

DETROIT LAKES, MINNESOTA

1435 Egret Avenue
Detroit Lakes, MN 56501
888.594.1394 • 888.594.1454/Fax

FONTANA, CALIFORNIA

14213 Whittram Avenue
Fontana, CA 92335
800.782.7953 • 909.829.9083/Fax

FORT SMITH, ARKANSAS

7510 Ball Road
Fort Smith, AR 72908
877.452.3915 • 479.646.5204/Fax

INDEPENDENCE, MISSOURI

1306 South Powell Road
Independence, MO 64057
800.747.0012 • 800.409.3069/Fax

JACKSONVILLE, FLORIDA

7110 Stuart Avenue
Jacksonville, FL 32254
800.394.4419 • 800.413.3292/Fax

JEFFERSON, OHIO

352 East Erie Street
Jefferson, OH 44047
800.321.5833 • 800.233.5719/Fax

MOCKVILLE, NORTH CAROLINA

188 Quality Drive
Mocksville, NC 27028
800.228.6119 • 800.228.7916/Fax

NASHVILLE, TENNESSEE

4314 Hurricane Creek Boulevard
Antioch, TN 37013
800.251.8508 • 800.419.4372/Fax

ROCK ISLAND, ILLINOIS

8111 29th Street West
Rock Island, IL 61201
800.747.1206 • 309.787.1833/Fax

ROGERS, MINNESOTA

22651 Industrial Boulevard
Rogers, MN 55374
800.328.9316 • 800.938.9119/Fax

SEATTLE, WASHINGTON

20213 84th Avenue South
Kent, WA 98032
800.431.3470 • 253.872.2008/Fax

SELLERSBURG, INDIANA

7800 State Road 60
Sellersburg, IN 47172
800.999.7777 • 800.477.9318/Fax

SIoux FALLS, SOUTH DAKOTA

2700 West 3rd Street
Sioux Falls, SD 57104
888.902.8320 • 800.938.9119/Fax

SPOKANE, WASHINGTON

2727 East Trent Avenue
Spokane, WA 99202
800.572.6565 • 509.534.4427/Fax

TEMPLE, TEXAS

3838 North General Bruce Drive
Temple, TX 76501
800.543.4415 • 800.543.4473/Fax

WOODLAND, CALIFORNIA

1326 Paddock Place
Woodland, CA 95776
800.759.6019 • 530.668.0901/Fax

Stay Connected: [!\[\]\(d51e873dec796bb1ee69b3bdb01466f2_img.jpg\)](#) [!\[\]\(1ee082fd769847d7f13b99ac01116171_img.jpg\)](#) [!\[\]\(a06bbb466108cdfa2fca9aeffc28827c_img.jpg\)](#)



ms metal sales™
manufacturing corporation